

DADO CIECO CON CALOTTA SFERICA

DIN 1587 – UNI 5721

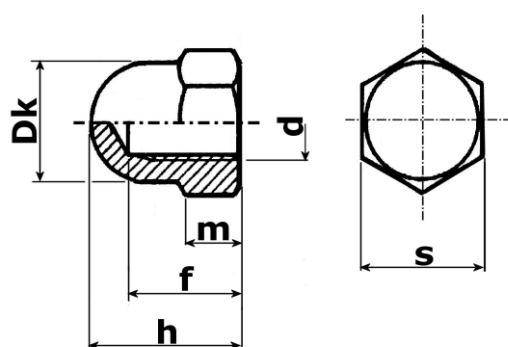

d	Passo Grosso	s	h	m	f	Dk	Kg~ per 1000 pezzi
M3	0,5	5,5	6,5	2,4	4	5	0,833
M4	0,7	7	8,5	3,2	5	6,5	1,350
M5	0,8	8	11	4	7	7,5	3,860
M6	1	10	13	5	8	9,5	4,660
M8	1	13	16	6,5	11	12,5	11,000
M10	1,5	17	19	8	13	16	20,100
M12	1,75	19	22	10	16	18	28,300
M14	2	22	25	11	18	21	57,200
M16	2	24	28	13	21	23	54,300
M18	2,5	27	32	15	25	26	95,000
M20	2,5	30	34	16	26	29	104,000
M22	2,5	32	39	18	29	31	128,000
M24	3	36	42	19	31	34	201,000

